

# RP453L



# RP453L

Paver

RP453L paver is a small type hydraulically driven wheeled paver with a reinforced E340T hydraulic screed, paving width ranges from 1.8m to 4.5m, and an electric heating and tamper compaction device. The machine is equipped with four-wheel drive and self-differential ASC technology, making it highly resistant to load and anti-slip performance, and is widely used in asphalt paving construction of municipal roads and rural roads, and asphalt pavement maintenance construction of classified highway.

## Performance and characteristics

- Driving speed up to 20km/h, allows quicker transportation.
- Full hydraulic axle drive automatic differential transmission system, rear four-wheel drive mode, good operability, large contact area and high traction force.
- 73.5kW power with ECO mode reducing fuel consumption and wear and tear.
- Independently driven conveyor and auger system, proportional adjustment of auger speed, strong operating ability and more responsive.
- 12t large hopper always store enough materials and adapt to different tonnage of trucks.

## Main dimensions

Unit: mm

Model	L	L1	L2	L3	L4	W	W1	W2	W3	H	H1	H2	$\alpha 1$	$\alpha 2$
RP453L	6260	5000	2212	2790	1040	3258	1884	1423	235	3745	3009	190	21.8°	21.1°

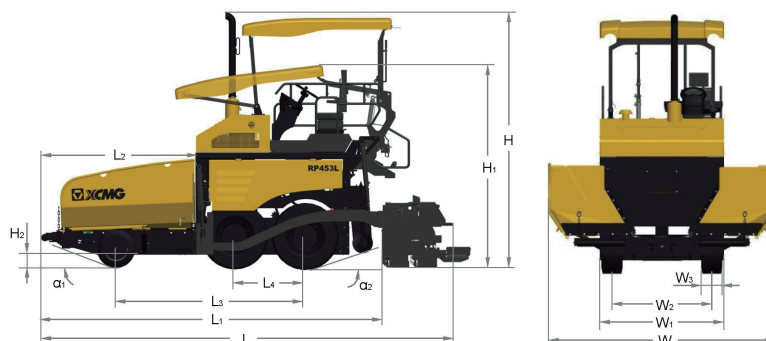

## Main specifications

Item	Content	Unit	RP453L
Basic parameters	Basic paving width	mm	1800
	Max. paving width	mm	4500
	Max. pave thickness	mm	260
	Max. paving speed	m/min	20
	Max. drive speed	km/h	20
	Maximum theoretical productivity	t/h	240
	Max. gradeability	%	20
Engine	Manufacturer	-	SDEC
	Model	-	SC4H100.1G3
	Emission	-	CHN Stage III
	Fuel	-	Diesel
	Rated power	kW	73.5
	Rated speed	rpm	2000
Tire	Front wheel numbers	-	2
	Front wheel dimension	mm	$\phi 559 \times 305$
	Rear wheel numbers	-	4
	Rear wheel dimension	mm	$\phi 974 \times 235$
Conveyor	Hopper capacity	t	12
	Scraper numbers	-	2
	Scraper speed(maximum)	m/min	24
Auger	Speed(maximum)	rpm	79
	Diameter	mm	300
Electrical system	Battery voltage	V	24
Weight	Tractor weight	t	9
	Operating weight	t	11
	Total weight	t	11.9
	Sound pressure level LPA at the operator ears	dB(A)	90.8
Noise	Emitted sound level	dB(A)	112
	Main configuration	1. Shangchai CHN Stage III engine with 73.5kW; 2. E340T hydraulic extending screed(electric heating, single tamper); 3. Standard intelligent control system; 4. MOBA leveling instrument/material level instrument.	
Options	1. E340T bolt-on extension: 2x0.575m, maximum paving width 4.5m; 2. Gas heating screed; 3. Diesel spray; 4. Cut-off shoes device.		