

# RP603L



# RP603L

Paver

RP603L is a medium-sized wheeled paver, equipped with E475T single tamper electric heating hydraulic extending screed. The infinite variable paving width, with the self-differential ASC, results in a stable and reliable paving quality and high adaptability. It is mainly applicable to the paving construction of asphalt pavement of graded highways and municipal roads, as well as repair and maintenance works of various roads. It is a perfect choice for where requires high flexibility.

## Performance and characteristics

- Full hydraulic axle drive automatic differential transmission system, rear four-wheel drive mode, good operability, large contact area and high traction force.
- 103kW power with ECO mode meet the needs of most working conditions, reducing fuel consumption and wear and tear.
- Highly elastic coupling with high vibration absorption capacity, with reinforced high torque brake, stable, reliable and durable.
- Independently driven conveyor and auger system, proportional

adjustment of auger speed, strong operating ability and more responsive.

- E475T telescopic screed with three-point suspension structure has strong bending and torsion resistance, which improves the evenness of the formed road surface.
- 13t large hopper always store enough materials and adapt to different tonnage of trucks.

## Main dimensions

Unit: mm

Model	L	L1	L2	L3	L4	W	W1	W2	W3	H	H1	H2	$\alpha_1$	$\alpha_2$
RP603L	6692	5117	2455	2988	1140	3285	2500	1929	276	4000	3180	196	16.7°	12.5°

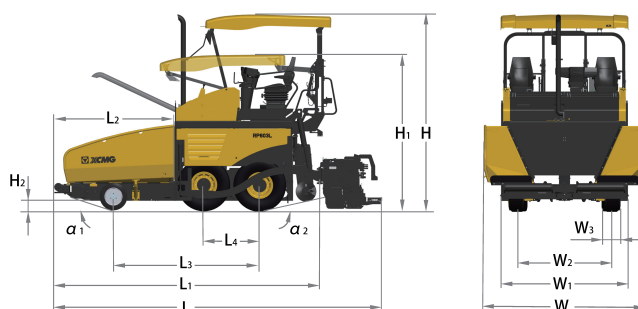

## Main specifications

Item	Content	Unit	RP603L
Basic parameters	Basic paving width	mm	2500~4750
	Max. paving width	mm	6000
	Max. pave thickness	mm	260
	Max. paving speed	m/min	17
	Max. drive speed	km/h	15
	Maximum theoretical productivity	t/h	400
	Max. gradeability	%	20
Engine	Manufacturer	-	SDEC
	Model	-	SC4H140.1G3
	Emission	-	CHN Stage III
	Fuel	-	Diesel
	Rated power	kW	103
	Rated speed	rpm	2200
Tire	Front wheel numbers	-	2
	Front wheel dimension	mm	$\phi$ 559×305
	Rear wheel numbers	-	4
	Rear wheel dimension	mm	$\phi$ 1073×276
Conveyor	Hopper capacity	t	13
	Scraper numbers	-	2
	Scraper speed(maximum)	m/min	24
Auger	Speed(maximum)	rpm	58
	Diameter	mm	420
Electrical system	Battery voltage	V	24
Weight	Tractor weight	t	15
	Operating weight	t	18
	Total weight	t	18.5
	Sound pressure level LPA at the operator ears	dB(A)	90.8
Noise	Emitted sound level	dB(A)	112.6
	Main configuration	1. Shangchai CHN Stage III engine with 103kW; 2. E475T hydraulic extending screed(electric heating, single tamper); 3. Standard intelligent control system; 4. MOBA leveling instrument/material level instrument; 5. Automatic centralized lubrication.	
Options	1. E475T bolt-on extension: 2×0.625m, maximum paving width 6m; 2. Gas heating screed; 3. Diesel spray.		